

Vx400

VOCAL EFFECTS
PROCESSOR
and USB COMPUTER
INTERFACE

User's Guide



DigTech[®]
The Power to Create

IMPORTANT SAFETY INFORMATION



The symbols shown above are internationally accepted symbols that warn of potential hazards with electrical products. The lightning flash with arrow point in an equilateral triangle means that there are dangerous voltages present within the unit. The exclamation point in an equilateral triangle indicates that it is necessary for the user to refer to the owner's manual.

These symbols warn that there are no user serviceable parts inside the unit. Do not open the unit. Do not attempt to service the unit yourself. Refer all servicing to qualified personnel. Opening the chassis for any reason will void the manufacturer's warranty. Do not get the unit wet. If liquid is spilled on the unit, shut it off immediately and take it to a dealer for service. Disconnect the unit during storms to prevent damage.

SAFETY INSTRUCTIONS

NOTICE FOR CUSTOMERS IF YOUR UNIT IS EQUIPPED WITH A POWER CORD.

WARNING: THIS APPLIANCE MUST BE EARTHED.

The cores in the mains lead are colored in accordance with the following code:

GREEN and YELLOW - Earth BLUE - Neutral BROWN - Live

As colors of the cores in the mains lead of this appliance may not correspond with the colored markings identifying the terminals in your plug, proceed as follows:

- The core which is colored green and yellow must be connected to the terminal in the plug marked with the letter E, or with the earth symbol, or colored green, or green and yellow.
- The core which is colored blue must be connected to the terminal marked N or colored black.
- The core which is colored brown must be connected to the terminal marked L or colored red.

This equipment may require the use of a different line cord, attachment plug, or both, depending on the available power source at installation. If the attachment plug needs to be changed, refer servicing to qualified service personnel who should refer to the table below. The green/yellow wire shall be connected directly to the units chassis.

CONDUCTOR	WIRE COLOR	
	Normal	Alt
L LIVE	BROWN	BLACK
N NEUTRAL	BLUE	WHITE
E EARTH GND	GREEN/YEL	GREEN

WARNING: If the ground is defeated, certain fault conditions in the unit or in the system to which it is connected can result in full line voltage between chassis and earth ground. Severe injury or death can then result if the chassis and earth ground are touched simultaneously.

LITHIUM BATTERY WARNING

CAUTION!

This product may contain a lithium battery. There is danger of explosion if the battery is incorrectly replaced. Replace only with an Eveready CR 2032 or equivalent. Make sure the battery is installed with the correct polarity. Discard used batteries according to manufacturer's instructions.

ADVARSEL!

Lithiumbatteri - Eksplosjonsfare. Ved utskifting benyttes kun batteri som anbefalt av apparatfabrikanten. Brukt batteri returneres apparatleverandøren.

ADVARSEL!

Lithiumbatteri - Eksplosjonsfare ved feilagtig håndtering. Utskiftning må kun ske med batteri av samme fabrikat og type. Levér det brukte batteri tilbake til leverandøren.

VAROITUS!

Paristo voi räjähtää, jos se on virheellisesti asennettu. Vaihda paristo ainoastaan laitevalmistajan suosittelemaan tyyppiin. Hävitä käytetty paristo valmistajan ohjeiden mukaisesti.

WARNING!

Explosionsfara vid felaktigt batteribyte. Använd samma batterityp eller en ekvivalent typ som rekommenderas av apparattillverkaren. Kassera använt batteri enligt fabrikantens instruktion.

ELECTROMAGNETIC COMPATIBILITY

This unit conforms to the Product Specifications noted on the **Declaration of Conformity**. Operation is subject to the following two conditions:

- this device may not cause harmful interference, and
- this device must accept any interference received, including interference that may cause undesirable operation.

Operation of this unit within significant electromagnetic fields should be avoided.

- use only shielded interconnecting cables.

IMPORTANT SAFETY INFORMATION

WARNING FOR YOUR PROTECTION

PLEASE READ THE FOLLOWING:

KEEP THESE INSTRUCTIONS

HEED ALL WARNINGS

FOLLOW ALL INSTRUCTIONS

DO NOT USE THIS APPARATUS NEAR WATER

CLEAN ONLY WITH A DRY CLOTH.

DO NOT BLOCK ANY OF THE VENTILATION OPENINGS. INSTALL IN ACCORDANCE WITH THE MANUFACTURER'S INSTRUCTIONS.

DO NOT INSTALL NEAR ANY HEAT SOURCES SUCH AS RADIATORS, HEAT REGISTERS, STOVES, OR OTHER APPARATUS (INCLUDING AMPLIFIERS) THAT PRODUCE HEAT.

ONLY USE ATTACHMENTS/ACCESSORIES SPECIFIED BY THE MANUFACTURER.

UNPLUG THIS APPARATUS DURING LIGHTNING STORMS OR WHEN UNUSED FOR LONG PERIODS OF TIME.

Do not defeat the safety purpose of the polarized or grounding-type plug. A polarized plug has two blades with one wider than the other. A grounding type plug has two blades and a third grounding prong. The wide blade or third prong are provided for your safety. If the provided plug does not fit your outlet, consult an electrician for replacement of the obsolete outlet.

Protect the power cord from being walked on or pinched, particularly at plugs, convenience receptacles, and the point where they exit from the apparatus.

Use only with the cart stand, tripod bracket, or table specified by the manufacture, or sold with the apparatus. When a cart is used, use caution when moving the cart/apparatus combination to avoid injury from tip-over.



Refer all servicing to qualified service personnel. Servicing is required when the apparatus has been damaged in any way, such as power-supply cord or plug is damaged, liquid has been spilled or objects have fallen into the apparatus, the apparatus has been exposed to rain or moisture, does not operate normally, or has been dropped.

POWER ON/OFF SWITCH: For products provided with a power switch, the power switch **DOES NOT** break the connection from the mains.

MAINS DISCONNECT: The plug shall remain readily operable. For rack-mount or installation where plug is not accessible, an all-pole mains switch with a contact separation of at least 3 mm in each pole shall be incorporated into the electrical installation of the rack or building.

FOR UNITS EQUIPPED WITH EXTERNALLY ACCESSIBLE FUSE RECEPTACLE: Replace fuse with same type and rating only.

MULTIPLE-INPUT VOLTAGE: This equipment may require the use of a different line cord, attachment plug, or both, depending on the available power source at installation. Connect this equipment only to the power source indicated on the equipment rear panel. To reduce the risk of fire or electric shock, refer servicing to qualified service personnel or equivalent.

U.K. MAINS PLUG WARNING

A molded mains plug that has been cut off from the cord is unsafe. Discard the mains plug at a suitable disposal facility. **NEVER UNDER ANY CIRCUMSTANCES SHOULD YOU INSERT A DAMAGED OR CUT MAINS PLUG INTO A 13 AMP POWER SOCKET.** Do not use the mains plug without the fuse cover in place. Replacement fuse covers can be obtained from your local retailer. Replacement fuses are 13 amps and **MUST** be ASTA approved to BS1362.

DECLARATION OF CONFORMITY

Manufacturer's Name: DigiTech
Manufacturer's Address: 8760 S. Sandy Parkway
Sandy, Utah 84070, USA

Declares that the product:

Product name: Vx400
Product option: all (requires Class II power adapter that conforms to the requirements of EN60065, EN60742, or equivalent.)

Conforms to the following Product Specifications:

Safety: IEC 60065 (1998)

EMC: EN 55013 (1990)
EN 55020 (1991)

Supplementary Information:

The product herewith complies with the requirements of the Low Voltage Directive 73/23/EEC and the EMC Directive 89/336/EEC as amended by Directive 93/68/EEC.

Vice-President of Engineering
8760 S. Sandy Parkway
Sandy, Utah 84070, USA
Date: May 23, 2003

European Contact: Your local DigiTech Sales and Service Office or

Harman Music Group
8760 South Sandy Parkway
Sandy, Utah
84070 USA
Ph: (801) 566-8800
Fax: (801) 568-7583

Warranty

We at **DigiTech** are very proud of our products and back-up each one we sell with the following warranty:

1. The warranty registration card must be mailed within ten days after purchase date to validate this warranty.
2. DigiTech warrants this product, when used solely within the U.S., to be free from defects in materials and workmanship under normal use and service.
3. DigiTech liability under this warranty is limited to repairing or replacing defective materials that show evidence of defect, provided the product is returned to DigiTech WITH RETURN AUTHORIZATION, where all parts and labor will be covered up to a period of one year. A Return Authorization number may be obtained from DigiTech by telephone. The company shall not be liable for any consequential damage as a result of the product's use in any circuit or assembly.
4. Proof-of-purchase is considered to be the burden of the consumer.
5. DigiTech reserves the right to make changes in design, or make additions to, or improvements upon this product without incurring any obligation to install the same on products previously manufactured.
6. The consumer forfeits the benefits of this warranty if the product's main assembly is opened and tampered with by anyone other than a certified DigiTech technician or, if the product is used with AC voltages outside of the range suggested by the manufacturer.
7. The foregoing is in lieu of all other warranties, expressed or implied, and DigiTech neither assumes nor authorizes any person to assume any obligation or liability in connection with the sale of this product. In no event shall DigiTech or its dealers be liable for special or consequential damages or from any delay in the performance of this warranty due to causes beyond their control.

NOTE: The information contained in this manual is subject to change at any time without notification. Some information contained in this manual may also be inaccurate due to undocumented changes in the product or operating system since this version of the manual was completed. The information contained in this version of the owner's manual supersedes all previous versions.

Table Of Contents

Introduction	1
Included Items	1
The Front Panel	1
Rear Panel	2
Making Connections	4
PA Rig	4
Recording Setup	4
Applying Power	5
The Presets	6
Performance	6
Bypass	6
Tuner	6
CD/Monitor In	7
Drum Machine	7
Mic Input and Level	7
Creating Presets	8
Editing/Creating Presets	8
The Matrix	8
Storing/Copying/Naming a Preset	8
About the Effects	10
Mic Modeling	10
Compressor/Noise Gate	11
Mic Pre/Voice	11
EQ	12
Mod Effects	12
Chorus	12
Flanger	12
Phaser	13
Tremolo	13
Vibrato	13
Strobe	13
Doublor	13
Envelope	14
Pixelator	14
Detune	14
Pitch	14
Whammy™	15
Delay	15
Reverb	15
Expression Pedal	16
V-Switch	17
Vx400 Setups	18
Setups Introduction	18
Instrument/Line Setups	18
Output Modes	19

The Vx400 and Recording	21
Recording Introduction	21
Connecting the Vx400 to the Computer	21
Vx400 Recording Setup	21
USB 1-2 Source	21
USB 3-4 Source	22
Mic Signal Routing	22
Mic USB Source Mapping	22
Instrument Signal Routing	23
Instrument USB Source Mapping	23
Line Signal Routing	24
Line USB Source Mapping	24
Using Pro Tracks	25
Installing Pro Tracks Software	25
Setting Up the DigiTech USB Control	25
Setting up the Vx400 for Hands-Free Recording	25
Setting up Pro Tracks for Vx400 Audio	26
Using the Vx400's Footswitches for Recording	27
Recording a Track or Tracks	27
Playing Back a Recorded Track	27
Recording Multiple Tracks	28
Using the UNDO Footswitch to Erase a Track	28
Re-Micing a Vocal Track	28
Vx400 Drums and MIDI	30
Recording the Vx400 Drums	30
Playback Mix	30
USB 1-2 Level /USB 3-4 Level	31
Using the RPxFC for Recorder Functions	31
Utilities	32
Factory Reset	32
Expression Pedal Calibration	32
V-Switch Sensitivity	32
Trouble Shooting Guide	33
Appendix	35
CC Parameter List	35
Factory Preset List	36
Specifications:	36

Introduction

- Knobs - These knobs perform various functions depending on which mode is selected or whether the Vx400 is connected to your computer via USB. During performance, the knobs control the Bass EQ, Mid EQ, Mid Frequency, Treble EQ, and Master Level. If the Vx400 is connected to the computer via USB, the performance functions of knobs 2, 3, and 4 are Playback Mix, USB 1-2 Send Level, and USB 3-4 Send Level. When editing or accessing the Setup functions, the knobs adjust the parameter values listed directly above each knob for the selected effect. When the Drum Machine is on, the knobs control the Pattern, Tempo, and Level. In Tuner mode, the knobs are used to select the tuning reference.
- Select Button - This button enters the Edit mode and selects individual effects to be edited. Successive presses of this button advances through all available effects. You can also use the select button to perform two shortcuts. First, you can exit from anywhere within Edit mode by pressing and holding the Select button. Second, you can move directly to the setup row of the Matrix while in Performance mode by pressing and holding the Select button.
- Drums - The Drums button turns the built-in drum machine on and off. When the drum machine is active, the Drums LED lights and the selected drum pattern plays continuously.
- Matrix - The matrix provides information regarding the current preset, and parameter edit functions. In performance mode, the LED's running down the left side of the Matrix identify which effects are in use for the selected preset. In Edit mode, the LED's indicate the effect selected for editing.
- Display - The display provides information for different functions depending on the mode that is active. In Performance mode, the display shows the selected preset name and numeric location. In Edit mode, the display shows the name and value of the selected parameter. In Tuner mode, the display shows the note being played and whether the note is sharp, flat, or in tune.
- Store - The Store button saves your changes to a User Preset.
- Expression Pedal - The Expression Pedal controls up to three of the Vx400's simultaneously assigned Effect Parameters in real time. Almost every Parameter is available for Expression Pedal control.

Rear Panel

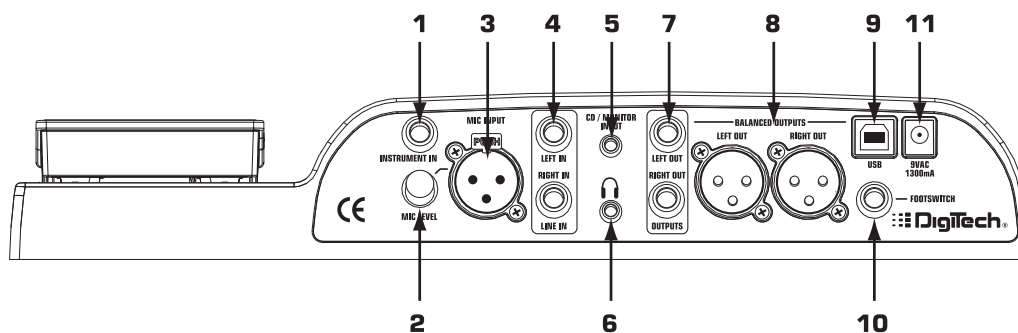

- Instrument In - Connect your instrument to this jack.
- Mic Level - Controls the gain of the Mic Input.

Introduction

3. Mic Input - Connect a mic here for recording or live performance mixing of acoustic sources into the Vx400. Mic signals can remain dry or be processed through the Vx400 effects for both live and recording applications. The Mic Input accepts either dynamic or phantom powered condenser microphones.
4. Left/Right Line Inputs - Connect line level sources to these jacks for recording or live performance mixing into the Vx400. Line signals can remain dry or be processed through the Vx400 effects for live and recording applications.
5. CD/Monitor In - Connect the output of a CD or MP3 player headphone out for listening to music. The CD/Monitor In can also be used as a monitor input for mixing the output of your computer's sound card back into the Vx400 for playback monitoring.

Note: Using the CD/Monitor input for any type of real-time recording monitoring may result in a time delay depending on your computer's speed.

6. Headphones - Connect a pair of stereo headphones to this 1/8" jack.
7. 1/4" Line Outputs - Connect these outputs to your amplifier or to a mixing console that accepts 1/4" unbalanced connections.
8. Balanced Line Outputs- Connect these outputs to your power amplifier/speaker system or to a mixing console that accepts balanced XLR connections.
9. USB Jack - Connect this jack to your computer's USB port for recording purposes (see page 25 for more on using the Vx400's USB functions).

ATTENTION: The Vx400 can be connected to your computer before installing the USB drivers if you are using Windows XP™. However, if you are using any software other than Windows XP, you must install the USB drivers provided on the X-Edit Software CD before connecting the Vx400 to your computer with the USB cable.

10. Footswitch jack - Connect the RPxFC 3-button footswitch to this jack. The RPxFC provides remote control of the recording functions of the Vx400 (see page 31 for more on using the RPxFC functions).
11. Power Input - Connect only the DigiTech PS0913B power supply to this jack.

Introduction

Making Connections

There are several different connection options available with the Vx400. Before connecting the Vx400, make sure that the power to your amplifier and the Vx400 is turned off. The Vx400 does not have a power switch. To turn the Vx400 off, disconnect the included PS0913B power supply from the power jack to an AC outlet.

PA Rig

Connect your microphone to the Input of the Vx400. Connect the balanced XLR Left and Right outputs to the inputs on your PA mixer and pan each of these channels hard left and hard right. Select FULL as your Output Mode (see **Output Modes** on pg 19 on how the XLR and 1/4" outputs can be implemented for various recording and live applications).

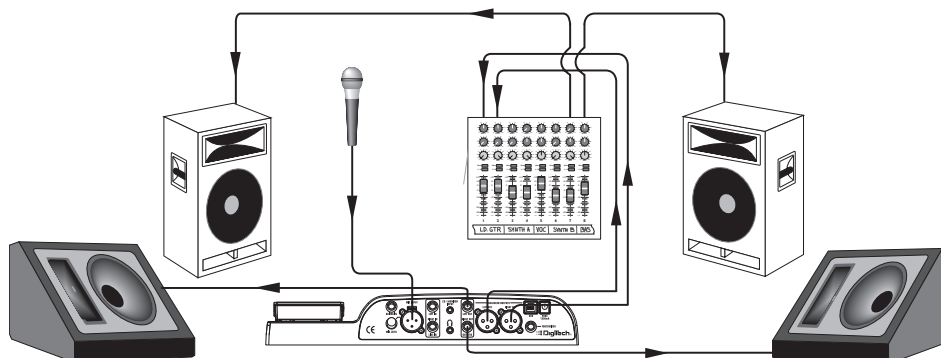

Recording Setup

This is the classic recording setup utilizing the Vx400's mic, instrument and line inputs with a pair of powered reference monitors connected the Vx400's XLR outputs. This setup can also be used for live applications where you would be performing along with playback from the Pro Tracks recording software running on your computer (see the **Output Modes** section on page 19 on how the XLR and 1/4" outputs can be implemented for various recording and live applications).

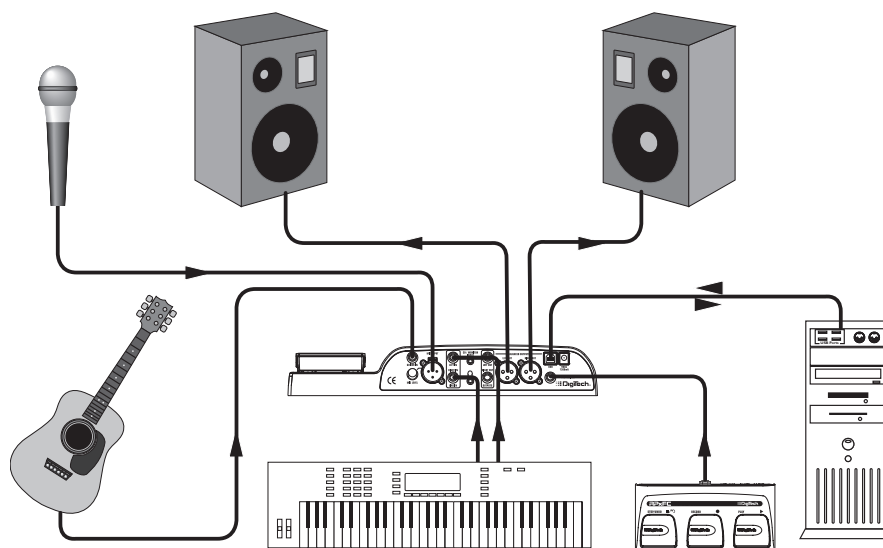

Introduction

Applying Power

Before applying power to anything, set your mixer to a flat EQ response (on most mixers, this would be 0). Then do the following:

1. Pull the Mixer's Master Faders down completely.
2. Connect the plug of the PS0913B power supply to the Power Jack.
3. Connect the other end of the PS0913B power supply to an AC outlet.
4. Turn the Vx400 Master Volume up to 70 (70%).
5. Push the Mixer's Master Faders up to your desired level.

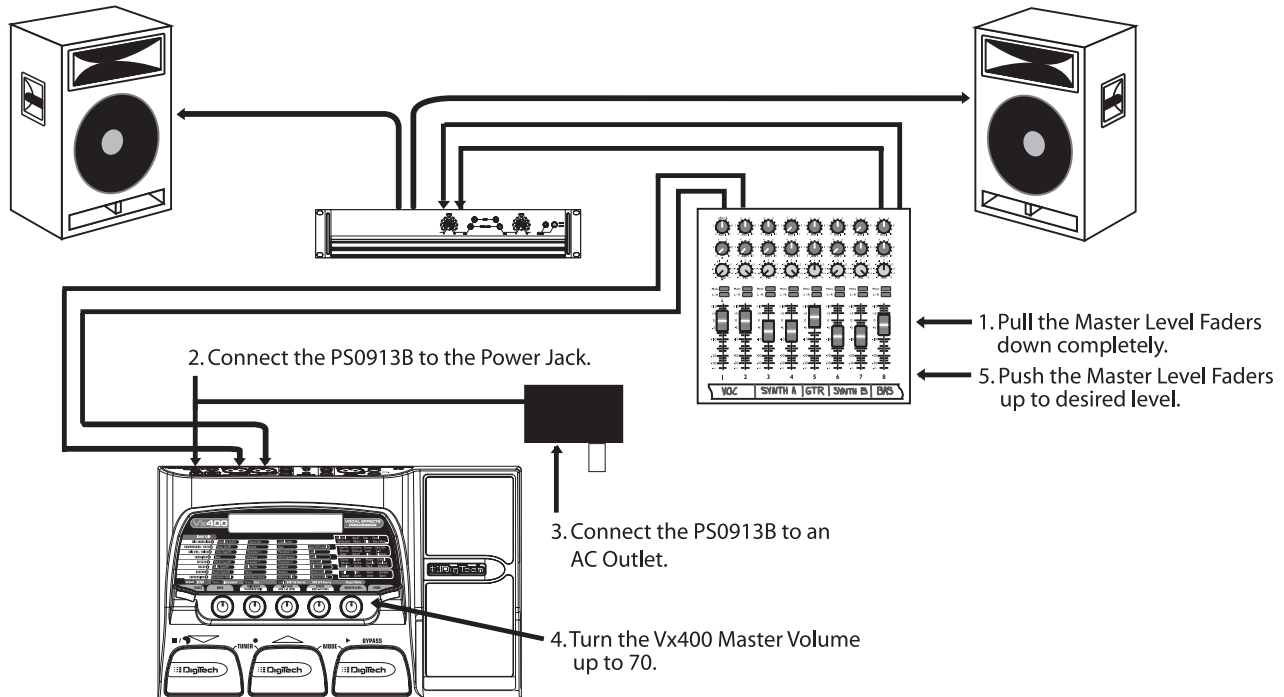

Introduction

The Presets

Presets are named and numbered locations of programmed sounds which reside in the Vx400. Presets are recalled with the footswitches. The active effects in each preset are indicated by the lighted LED's in the Effect Matrix. The Vx400 comes with 40 User Presets (Presets 1-40), and 40 DigiTech factory presets (41-80). The User Presets are locations where you can store your edits. You may not store changes to the Factory Presets. From the factory, the 40 User Presets are exact duplicates of the 40 Factory Presets.

Performance

When you first apply power to the Vx400, it powers up in Performance mode. Performance mode provides access to all of the presets within the Vx400 via the Up and Down Footswitches. The Number 1 Knob (left) adjusts the Bass, the Number 2 Knob (second from the left) adjusts the amount of Midrange enhancement, the Number 3 Knob (middle) adjusts the Mid Frequency, the Number 4 Knob (second from the right) adjusts the amount of Treble (high frequency) enhancement, and the Number 5 Knob (right) adjusts the Master Level (volume).

Bypass

The Vx400 Presets can be bypassed for clean, unprocessed vocals and instrument signals. To bypass the Vx400, press the **BYPASS** Footswitch. The display will read Bypass indicating the preset is bypassed. Pressing the Up or Down Footswitches advances to the next available preset. Pressing the Bypass Footswitch again exits you from Bypass and loads that preset.

Tuner

The Tuner lets you quickly tune or check the tuning of any instrument plugged into the Vx400. Enter Tuner mode by pressing and holding the Up and Down Footswitches simultaneously. The display briefly shows *TUNER* indicating that you are in Tuner mode. To begin tuning, play a note on your instrument (a harmonic at the 12th fret usually works best for guitars). The right 2 characters in the display shows the note being played. The left characters in the display indicate whether you are sharp or flat. Arrows pointing to the left (<<<) indicate the note is sharp and should be tuned down. Arrows pointing to the right (>>>) indicate the note is flat and should be tuned up. When the note is in tune, the display shows --- > < ---.

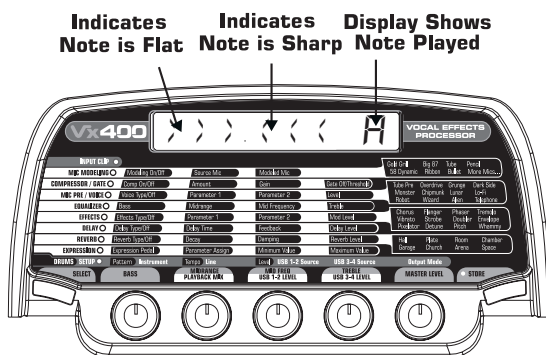

In Tuner mode, you can change your tuning reference. The default factory setting is A=440 Hz. (displayed as A=440). Rotate the Number 1 Knob to select alternate dropped tunings. Alternate tunings are A = Ab , A = G , and A = Gb. The display window briefly flashes the selected tuning preference.

The output is muted in Tuner mode. The Expression Pedal returns sound to the output allowing signal to be heard while tuning. Exit tuner mode by pressing any of the 3 Footswitches.

Introduction

CD/Monitor In

The CD In feature lets you connect a CD, MP3, or tape player to the Vx400, and play along with your favorite artists. To use the CD In feature, do the following:

1. Connect the headphone output of your MP3/CD/tape player to the CD/Monitor input using an 1/8" stereo cable.
2. Press play on your MP3/CD/tape player. The signal from your MP3/CD/tape player is routed to the left, right, and headphone outputs of the Vx400.

The Monitor In feature can also be used as a monitor input for mixing the output of your computer's sound card back into the Vx400 for playback monitoring.

Drum Machine

The Vx400 features a Drum machine that includes several sampled drum patterns which are useful for developing a good sense of timing. Pressing the Drums button turns on the built-in drum machine (except when in Store or Bypass mode). When the drum machine is active:

The Number 1 Knob is used to select the drum Pattern. Choices include:

ROCK 1	HROCK4	DANCE1	BLUES2	URBAN1
ROCK 2	POP1	DANCE2	JAZZ	URBAN2
ROCK 3	POP2	DANCE3	FUNK 1	REGGAE
HROCK1	POP3	ENTRY1	FUNK 2	CHA 1
HROCK2	POP4	ENTRY2	SWING1	CHA 2
HROCK3	POPS	BLUES1	SWING2	BOSSA
				MTRNDM

The Number 2 Knob adjusts the drum Tempo and ranges from BPM 40 (40 beats per minute) to BPM240 (240 beats per minute).

The Number 3 Knob adjusts the volume Level of the drum loop and ranges from 1 to 99.

Press the Drums button again to stop playback of the drum loop.

Mic Input and Level

The Vx400 features a mic input that can be used for mixing or recording vocals and acoustic instruments. The mic input is equipped with phantom power that can power professional condenser microphones. The mic preamp is controlled via the Mic Level knob for controlling the gain of the mic signal. To set the mic level control, follow these steps:

1. Connect a set of headphones to the headphone jack.
2. Sing or play at the loudest volume you will be performing at and adjust the mic Level control until you see the Clip LED at the top of the Matrix light. Then gradually decrease the control until the light goes out. This is the optimum setting for the Mic Level.

For application uses of the mic input, see both the **Making Connections** and **Vx400 Setups** sections of this user's guide.

Creating Presets

3. Rotate Knob 2 clockwise to select the next character, and counterclockwise to select the previous character. Repeat step 2 until the name is complete.



1. Press Store and Characters in Display Flash Individually

2. Number 1 Knob Selects Alpha-Numeric Characters

3. Number 2 Knob Selects Next or Previous Characters in Display

4. Once the name is shown in the display, press the Store button. The display will then flash the new name of the preset.
5. Select the User Preset location of your new preset using Knob 5 or the Up/Down Footswitches. The display will then flash the new name of the preset.

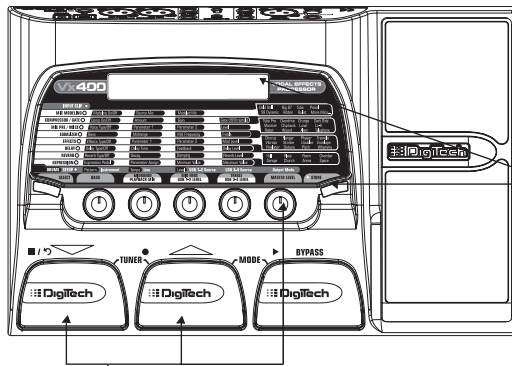

4. Press Store Again Preset Name and Numeric Location Flash in Display

5. Select Numeric Destination with Footswitches or Number 5 Knob

6. Press the Store button again to save the changes.

Press the Select or Drums buttons at any time to abort storing.

To copy one preset to another preset location is the same as above. Use the footswitches to select the preset that you want to copy, then follow the steps listed above.

Creating Presets

Vx400's Effects

About the Effects

The Vx400 can be thought of as having several different microphone and rack effect processors in a single programmable package. The order in which they are connected can drastically affect the overall sound quality. The Vx400 has placed the effects in an order for optimum sound quality. The following diagram shows the order of the effects.

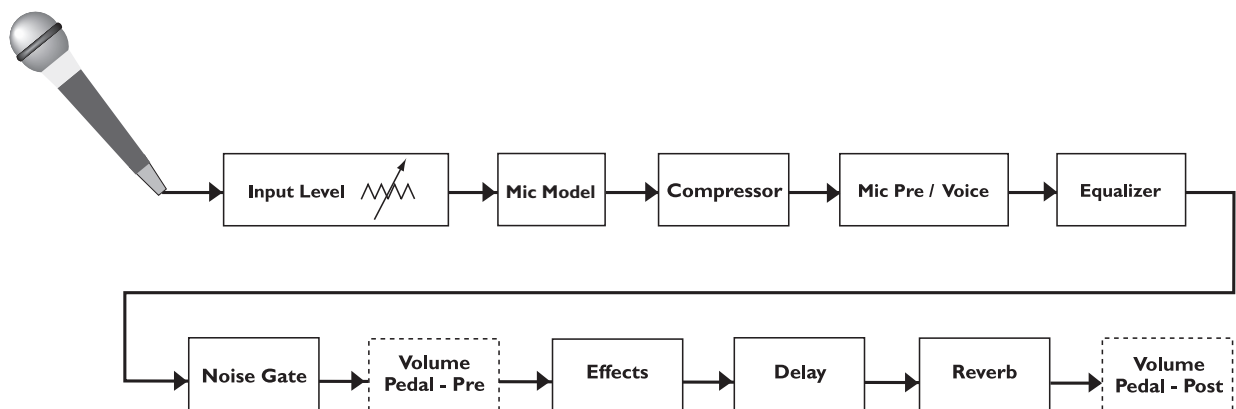

Effect Definitions

Each effect within the Vx400 can be programmed to suit your personal taste and application. Understanding how these effects alter the sound, and how each parameter alters the effect helps you achieve the sound you are looking for. The following overview of the Vx400's effects outlines what each effect and parameter does.

Mic Modeling

Using proprietary algorithms, DigiTech engineering built precise models of a variety of popular microphones. This technology allows you to make a composite microphone model by removing the characteristics of a typical dynamic or condenser mic and adding the characteristics of the desired microphone sound.

Modeling On/Off - The Number 1 Knob turns the Mic Modeling effect on (ON) and off (OFF).

Source Mic - The Number 2 Knob selects your Source Mic type. There are two types to choose from, (Dynamic (DYNAMIC) or Condenser (CONDEN)).

Modeled Mic - The Number 3 Knob selects the Mic Model type. See list below for Mic Model types and descriptions.

Microphone Model Descriptions/Display Names

Microphone	Description	Display Name
AKG™ 414 TLII	Large Diaphragm Condenser	GLDGRL
Neumann™ U87 AI	Large Diaphragm Condenser	BIG 87
AKG™ C12	Large Diaphragm Tube	TUBE
Oktava™	Small Diaphragm Condenser	PENCIL
Shure™ SM58	Small Diaphragm Dynamic	SB DYN
Royer™ 121	Ribbon Microphone	RIBBON

Creating Presets

Shure™ Green Bullet	Large Diaphragm Dynamic - Harmonica Mic	BULLET
Brawner™ VMI	Large Diaphragm Condenser	BRAWNY
Neumann™ M149	Large Diaphragm Condenser	NEU149
Lawson™ L47MP	Large Diaphragm Tube	LAWLES
AKG™ 414 ULS	Large Diaphragm Condenser	SLVGR
Sennheiser™ 421 MD	Large Diaphragm Dynamic	SENDYN
Audio Technica™ AT4050	Large Diaphragm Condenser	ATCOND
Neumann™ KM184	Large Diaphragm Condenser	NEU184
Scheops™ MK21	Small Diaphragm Condenser	SHEP21
Shure™ KSM32	Large Diaphragm Condenser	KISSEM

Shure, AKG, Audio Technica, Neumann, Lawson, Oktava, Royer, Brawner, Sennheiser, and Scheops are Registered trademarks of their respective companies. The aforementioned names and models are used solely to indicate microphones used for analysis in the development of this product. It is not implied in any way that there is any association with or endorsement by any of the named manufacturers.

Compressor/Noise Gate

The Compressor/Noise Gate module is used to control the dynamics of varying signal strengths and eliminate unwanted noise when a signal isn't present.

Comp On/Off - The Number 1 Knob turns the Compressor on (ON) and off (OFF).

Amount - Rotate the Number 2 Knob to adjust the amount of Compression you want applied to the signal. Ranges from 1 to 20.

Gain - Rotate the Number 3 Knob to increase the compressor's output gain. Ranges from 0 to 10dB.

Gate Off/Threshold - Rotate the Number 4 Knob to turn the Noise Gate off (OFF) and to adjust the threshold level. Ranges from 1 to 99. A higher setting requires a stronger signal to open the gate.

Mic Pre/Voice

This module selects various Mic Preamp and Voice character types. Tube Pre is a warm professional mic preamp type for standard vocal usage. Overdrive and Grunge are cutting edge distortion preamp types. The other nine voice characters produce wild and unnatural vocal sounds.

Voice Type/Off - The Number 1 Knob selects a vocal type and turn the Mic Pre/Voice types on (ON) and off (OFF) (see Mic Pre/Voice Type Parameter chart following these for parameter descriptions).

Parameter 1 - The Number 2 Knob adjusts the first parameter of the Voice type selected (see Voice Parameter chart following these instructions).

Parameter 2 - The Number 3 Knob adjusts the second parameter of the Voice type selected (see Voice Parameter chart following these instructions).

Level - The Number 4 knob controls the preset level for the selected type. Ranges from 0 to 99

Master Level - The Number 5 Knob controls the Vx400's Master Level.

Mic Pre / Voice Parameters

Voice Type	Param 1	Range	Param 2	Range
Direct	-----	-----	-----	-----
Tube Pre	GAIN	0-15	DE ESS	1-50
Overdrive	GAIN	0-50	DE ESS	1-50
Grunge	GAIN	0-50	DE ESS	1-50

Creating Presets

Dark Side	<i>BREATH</i>	1-20	-----	-----
Monster	<i>SIZE</i>	1-60	<i>GROWL</i>	1-40
Chipmunk	<i>SIZE</i>	1-30	-----	-----
Lunar	<i>RANGE</i>	1-10	-----	-----
Lo-Fi	<i>DRIVE</i>	0-50	<i>SUBFRQ</i> (Sub Freq.)	1-18
Robot	<i>RANGE</i>	1-50	<i>EDGE</i>	1-50
Wizard	<i>RANGE</i>	1-50	-----	-----
Alien	<i>RATE</i>	1-40	<i>INTENS</i> (Intensity)	1-50
Telephone	<i>SUBFRQ</i> (Sub Freq.)	1-35	<i>SIBLNC</i> (Sibilance)	1-50

EQ

The EQ module is a 3-band EQ consisting of Bass, Midrange, and Treble. The frequency centers for each band may vary depending on the selected model.

Bass - The Number 1 Knob adjusts the low frequency gain. Ranges from -12 to +12dB.

Midrange - The Number 2 Knob adjusts the midrange frequency gain. Ranges from -12 to +12dB.

Mid Frequency - The Number 3 Knob adjusts the midrange frequency. Ranges from 100Hz to 4000Hz.

Treble - The Number 4 Knob adjusts the high frequency gain. Ranges from -12 to +12dB

Mod Effects

The Effects row in the Vx400 is a multi-function module allowing you to select effects such as: Chorus, Flanger, Phaser, Tremolo, Vibrato, Strobe, Doubler, Envelope, Pixelator, Detune, Pitch, and Whammy™ effects. When the Effects row is selected, the Number 1 Knob is used to turn the Effect module on or off (*EFFECT ON*), and select the type of Effect to be used. After selecting the type of effect in this module, the Number 2-4 Knobs can then be used to adjust the individual Parameters associated with the selected effect. The Number 5 Knob controls the Vx400's Master Level. The following describes each Effect and their Parameters in more detail:

Chorus

A Chorus adds a short delay to your signal. The delayed signal is modulated in and out of tune and then mixed back with the original signal to create a thicker sound.

Parameter 1 - The Number 2 Knob adjusts the rate (Speed) of the modulation. Ranges from 1 to 99.

Parameter 2 - The Number 3 Knob adjusts the intensity (Depth) of the modulation. Ranges from 1 to 99.

FX Level - The Number 4 Knob controls the volume of the Chorus. Ranges from 0 to 99.

Master Level - The Number 5 Knob controls the Vx400's Master Level.

Flanger

A Flanger uses the same principle as a Chorus but uses a shorter delay time and adds regeneration (or repeats) to the modulating delay. This results in an exaggerated up and down sweeping motion to the effect.

Parameter 1 - The Number 2 Knob adjusts the rate (Speed) of the modulation. Ranges from 1 to 99.

Parameter 2 - The Number 3 Knob adjusts the intensity (Depth) of the modulation. Ranges from 1 to 99.

FX Mix - The Number 4 Knob controls the mix of wet and dry signal. Ranges from 0 (all dry) to 99 (all wet).

Creating Presets

Master Level - The Number 5 Knob controls the Vx400's Master Level.

Phaser

A Phaser splits the incoming signal, and then changes the phasing of the signal. This signal is then taken in and out of phase and mixed back in with the original signal. As the phasing changes, different frequencies get canceled resulting in a warm sort of twisting sound.

Parameter 1 - The Number 2 Knob adjusts the rate (Speed) of the modulating phase. Ranges from 1 to 99.

Parameter 2 - The Number 3 Knob adjusts the intensity (Depth) of the modulating phase. Ranges from 1 to 99.

FX Level - The Number 4 Knob controls the volume of the Phaser. Ranges from 0 (all dry) to 99.

Master Level - The Number 5 Knob controls the Vx400's Master Level.

Tremolo

A Tremolo effect modulates the volume of the signal at an even rate.

Parameter 1 - The Number 2 Knob adjusts the rate (Speed) the volume modulates. Ranges from 1 to 99.

Parameter 2 - The Number 3 Knob adjusts the intensity (Depth) of the modulating volume. Ranges from 0 (all dry) to 99.

The Number 4 Knob has no function when the Tremolo effect is selected.

Master Level - The Number 5 Knob controls the Vx400's Master Level.

Vibrato

A Vibrato effect modulates the pitch of the incoming signal at an even rate.

Parameter 1 - The Number 2 Knob adjusts the rate (Speed) at which the pitch modulates. Ranges from 1 to 99.

Parameter 2 - The Number 3 Knob adjusts the intensity (Depth) of the modulating pitch. Ranges from 1 to 99.

The Number 4 Knob has no function when the Vibrato effect is selected.

Master Level - The Number 5 Knob controls the Vx400's Master Level.

Strobe

The Strobe is a tremolo effect that uses a square wave LFO for the modulation of the signal.

Parameter 1 - The Number 2 Knob to adjust the rate (Speed) at which the LFO modulates. Ranges from 1 to 99.

Parameter 2 - The Number 3 Knob controls the intensity (Depth) of the Effect. Ranges from 0 to 99.

The Number 4 Knob has no function when the Strobe effect is selected.

Master Level - The Number 5 Knob controls the Vx400's Master Level.

Doubler

The Doubler effect adds a slightly delayed signal to the input signal creating a thicker sound as the level is increased.

FX Level - The Number 4 Knob controls the volume of the doubled signal. Ranges from 0 (all dry) to 99 (all wet).

The Number 2, and 3 Knobs have no function when the Doubler effect is selected.

Creating Presets

Master Level - The Number 5 Knob controls the Vx400's Master Level.

Envelope

The Envelope is an automatic Wah effect that alters your sound based upon the dynamic attack of the vocal part being sung or instrument being played.

Parameter 1 - The Number 2 Knob adjusts the amount of Wah sweep once the Wah is triggered. Ranges from 1 to 99.

Parameter 2 - The Number 3 Knob adjusts the sensitivity or the input signal required to trigger the Wah effect. Ranges from 1 to 99.

FX Mix - The Number 4 Knob controls the mix of wet and dry signal. Ranges from 0 (all dry) to 99 (all wet).

Master Level - The Number 5 Knob controls the Vx400's Master Level.

Pixelator

The Pixelator effect removes random samples from the input signal which in turn reduces the signal's quality and creates a granular type effect on the source. Higher Amount settings remove more samples which reduces the signal's intelligibility.

Parameter 1 - The Number 2 Knob adjusts the amount of random samples being removed from the source signal. Ranges from 1 to 50.

Parameter 2 - The Number 3 Knob adjusts the edge of where the sample is being removed. Ranges from 0 to 99.

FX Mix - The Number 4 Knob controls the mix of wet and dry signal. Ranges from 0 (all dry) to 99 (all wet).

Master Level - The Number 5 Knob controls the Vx400's Master Level.

Detune

A Detuner will make a copy of your incoming signal, take the copied signal slightly out of tune from the original, and mix the two signals together. The result is a doubling type of effect as if two vocal parts were being sung together or two instruments were playing the same part together.

Parameter 1 - The Number 2 Knob adjusts the amount of pitch difference applied to the copied signal. Ranges from -24 to 24.

FX Level - The Number 4 Knob controls the volume of the detuned note. Ranges from 0 to 99. Knob's 3 has no function when the Detune effect is selected.

Master Level - The Number 5 Knob controls the Vx400's Master Level.

Pitch

A Pitch Shifter copies the incoming signal, then shifts the pitch of the copied note to a different note. The shifted note is then mixed back with the original signal sounding as if two vocal parts were being sung in harmony or two instruments were playing in harmony.

Parameter 1 - The Number 2 Knob adjusts the interval of shifted pitch. Ranges from -24 (semitones below) to 24 (24 semitones above).

FX Level - The Number 4 Knob controls the volume of the shifted pitch. Ranges from 0 to 99. The Number 3 Knob has no function when the Pitch Shift effect is selected.

Master Level - The Number 5 Knob controls the Vx400's Master Level.

Creating Presets

Whammy™

Whammy™ is an effect that uses the Expression Pedal to bend the pitch of the incoming signal, or add a bendable harmony with the original signal. As the Pedal is moved, the note will bend either up or down. The Whammy™ effect must be linked to the Expression Pedal in order to function. See page 16 for more information on linking the Expression Pedal.

Parameter 1 - The Number 2 Knob selects the interval and direction of the pitch bend. Choices are as follows:

Whammy (no Dry Signal)

1OCTUP (1 octave above)
2OCTUP (2 octaves above)
2ND↓WN (a second below)
REV 2ND (a second below reversed pedal action)
4TH↓WN (a fourth below)
1OCT↓N (an octave below)
2OCT↓N (2 octaves below)
DIVE BOMB (Dive Bomb)

Harmony Bends (Dry Signal Added)

M3>M3 (a minor third to a Major third)
2ND↑M3 (a second above to a Major third above)
3RD↑4TH (a third above to a fourth above)
4TH↑5TH (a fourth above to a fifth above)
5TH↑OCT (a fifth above to an octave above)
HOCTUP (one octave above)
HOCT↓N (one octave down)
OCTU>↓ (one octave up to one octave down)

FX Level - The Number 4 Knob adjusts the volume of the Whammy™. Ranges from 0 to 99.

The Number 3 Knob has no function when the Whammy™ is selected.

Master Level - The Number 5 Knob controls the Vx400's Master Level.

Note: Only one of the effects in the Effects row can be used at a time.

Delay

Delay is an effect that will record a portion of the incoming signal, and then play it back a short time later. The recording can repeat just once, several times, or infinitely (which turns off the input to the Delay and allows you to play over the top of a passage in the Delay loop).

Delay Type/Off - The Number 1 Knob turns the Delay on (ON) and off (OFF) and selects one of the 3 different types of Delay. Values include: DIGITAL (Digital Delay), ANALOG (Analog Delay), P PONG (Ping Pong Delay).

Delay Time - The Number 2 Knob adjusts the amount of Delay time. Ranges from 10 MS through 2 SEC (10 ms through 1 sec in 10 ms increments and 1 sec through 2 sec in 100 ms increments).

Feedback - The Number 3 Knob adjusts the number of times the delayed signal will repeat. Ranges from 1 to 99 and repeat hold (infinite repeat).

Delay Level - The Number 4 Knob adjusts the volume of the delayed signal. Ranges from 0 to 99.

Master Level - The Number 5 Knob controls the Vx400's Master Level.

Reverb

Reverb can give the listener a sense that the material is being performed in various acoustical environments. It can provide the tight acoustics of a small room, or the ambience of huge arena.

Reverb Type/Off - The Number 1 Knob selects the Type of Reverb or acoustic environment and turns the Reverb off (OFF) or on (ON). The Vx400 provides your choice of eight different environments including:

Creating Presets

HALL = Hall *GARAGE* = Parking Garage
PLATE = Plate *CHURCH* = Church
ROOM = Wood Room *ARENA* = Arena
CHAMBER = Chamber *SPACE* = Space

Decay - The Number 2 Knob adjusts the length of time the Reverb is audible. Ranges from 1 to 99.

Damping - The Number 3 Knob controls the amount of sound which is absorbed in the simulated environment. Ranges from 0 to 99.

Reverb Level - The Number 4 Knob adjusts the volume of the Reverb. Ranges from 0 to 99.

Master Level - The Number 5 Knob controls the Vx400's Master Level.

Expression Pedal

The Expression Pedal on the Vx400 can be assigned to control the Vx400's Volume, Whammy™, or just about any other parameter in real time with your foot. When a parameter has been assigned to the Expression Pedal, a programmable minimum and maximum value can also be assigned. The procedure for assigning a parameter to the Expression Pedal is as follows:

1. Select a User or the Factory Preset.
2. Press the **SELECT** button until the light in the Expression row of the Matrix's LED begins flashing.
3. Rotate the Number 1 Knob to select the Expression pedal 1,2, or 3.

Note: You can assign three parameters to the Expression pedal per preset.

4. Rotate the Number 2 Knob to select the parameter the pedal will control.
5. Rotate the Number 3 Knob to adjust the minimum value the pedal (toe up) reaches.
6. Rotate the Number 4 Knob to adjust the maximum value the pedal (toe down) reaches.
7. Press the **STORE** button to store the changes. See page 8 for more information on storing presets.

The following is a list of the parameters that can be assigned to the Expression pedal:
(Voice and Effect Parameters depend on the type that is currently selected).

Parameter	Display	Min Value	Max Value
Voice Param 1	Varies	Varies	Varies
Voice Param 2	Varies	Varies	Varies
Voice Level	VOLVL	1	99
Effect Speed	PARAM 1	Varies	Varies
Amount/Depth	PARAM 2	Varies	Varies
Effect Level	FXLEVL	0	99
Effect Mix	FX MIX	0	99
Whammy	WHMAMT	1	99
Delay Feedback	FBACK	1	99 R-hold
Delay In Level	DLY IN	0	99
Delay Out Level	DLY OUT	0	99
Reverb Decay	DECAY	1	99
Reverb In Level	RVB IN	0	99
Reverb Out Level	RVB OUT	0	99
Volume Pre	VOLPRE	----	----
Volume Post	VOLPOST	----	----

Creating Presets

V-Switch

The Vx400's Expression Pedal includes DigiTech's exclusive V-Switch. The V-Switch allows the Voice Type to be switched on and off. Applying extra pressure to the toe of the Expression Pedal will engage the V-Switch and the function of the Expression Pedal will switch between the assigned parameter and Voice off. The sensitivity or amount of pressure required to engage the V-Switch can be adjusted to suit your personal taste (or weight of your foot). See page 32 for the V-Switch Sensitivity adjustment procedure.

Vx400 Setups

Setups Introduction

The Vx400 is equipped with four inputs and four outputs that can be configured several different ways for both live and recording applications. These configurations are selected in the **DRUMS/SETUP** row of the editing matrix using the five editing knobs. Settings include whether the Instrument or Line inputs are routed through the Vx400's effects processing and which pair of outputs mic, line, and instrument processing are routed to. The **USB 1-2 Source** and **USB 3-4 Source** knobs are used for configuring how all inputs, mic processing, and drum machine are routed via USB to the computer for recording applications.

Instrument/Line Setups

The Instrument and Line Setups are configurations for the instrument and line inputs designed primarily for live performance applications. The Vx400 acts as a mixing device for mic, instrument, and line sources, and can eliminate the need for a mixer when the Vx400's outputs are to be plugged directly into a full-range powered speaker system. When enabled, these inputs can be routed around or through the Vx400's effects processing and then mixed directly into the Vx400's 1/4" and XLR outputs.

Both Instrument and Line inputs have four settings that can be independently selected using the **Instrument** and **Line** knobs in the **DRUMS/SETUP** row of the effect matrix. The configurations are as follows:

INSOFF / LINSOFF - Instrument and Line inputs are disabled.

INSBYP / LINBYP - Inputs routed directly to Vx400's outputs, bypassing all effects processing.

INSRVB / LINRVB - Inputs routed through delay and reverb effects of the current preset.

INSFX / LINEFX - Inputs routed through all effects of current preset.

Instrument Routing

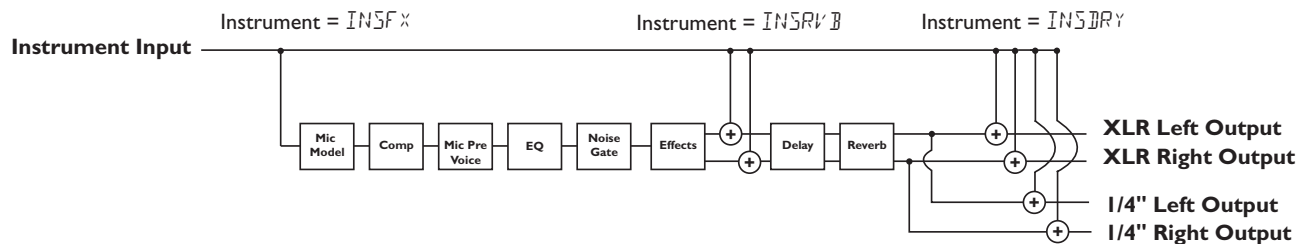

Line Input Routing

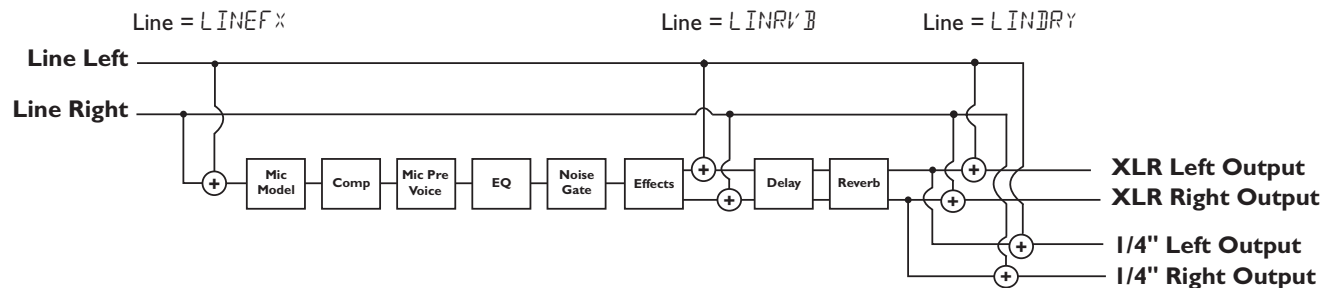

Vx400 Setups

Output Modes

The Vx400 features both 1/4" and XLR outputs on the rear panel. These jacks let you simultaneously connect the Vx400 to an amplifier/speaker system on stage via the 1/4" outputs and connect directly to your PA system via the XLR outputs.

The five output modes for the Vx400 are as follows:

FULL - All input sources are routed out 1/4" and XLR outputs.

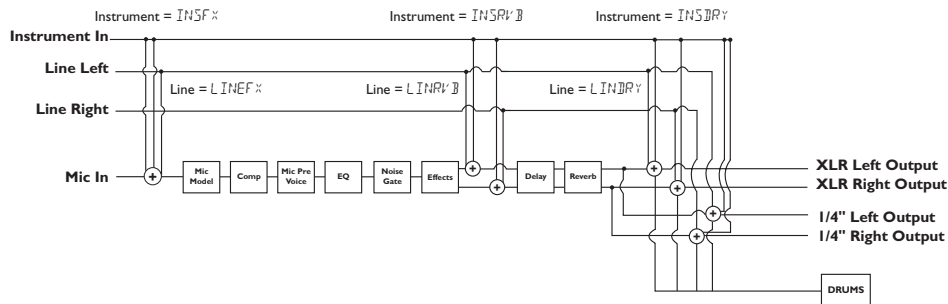

XLR DRY - The dry Mic signal is routed out the XLR outputs only. All other sources and Mic with all Effects are routed out the 1/4" outputs.

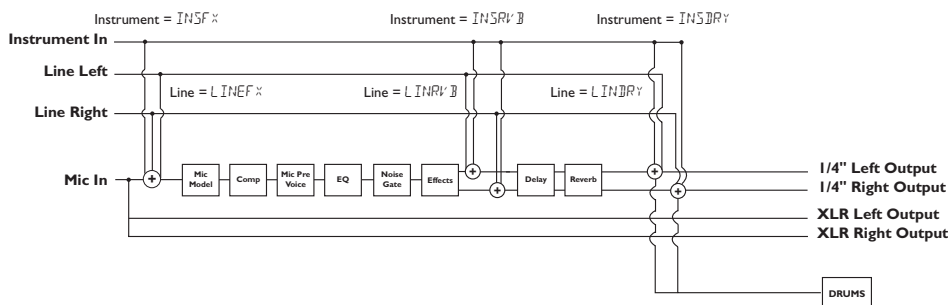

XLR MOD - The Mic signal with Modulation Effects is routed out the XLR outputs only. All other sources and Mic with all Effects are routed out the 1/4" outputs.

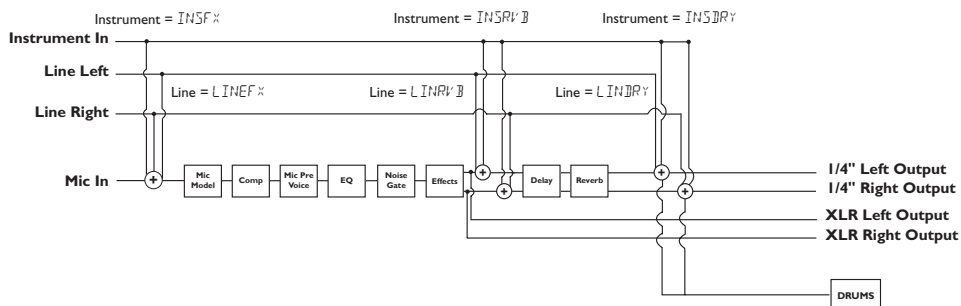

Vx400 Setups

1/4 DRY - The dry Mic signal is routed out the 1/4" outputs only. All other sources and Mic with all Effects are routed out the XLR outputs.

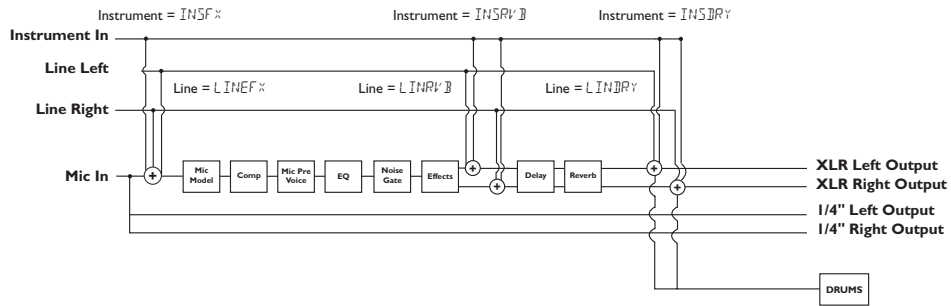

1/4 MOD - The Mic signal with the Modulation Effects is routed out the 1/4" outputs only. All other sources and Mic with all Effects are routed out the XLR outputs.

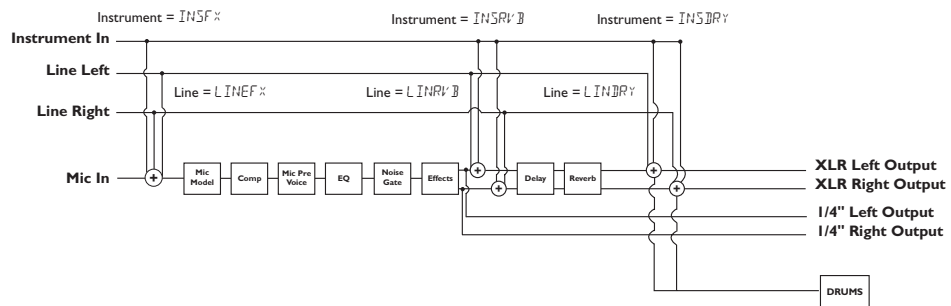

The Vx400 and Recording

Recording Introduction

The Vx400's USB connection provides 4 channels of audio streaming into the computer and 2 channels of playback from the computer simultaneously. Recording has never been easier thanks to the hands-free tracking environment that the Vx400 and Pro Tracks™ software provide. The Vx400's footswitches and Pro Tracks software work seamlessly together to automatically arm, record, play, and delete tracks totally hands free. Multiple recording configurations can be selected to best optimize your recording needs. These configurations are accessed via the Vx400's effect's matrix in the **DRUMS/SETUP** row.

To begin recording you must first install the proper USB drivers and Pro Tracks recording software onto your Windows® compatible PC. The USB drivers are found on the X-Edit™ Software CD that came packaged with the Vx400 and the Pro Tracks recording software CD is found in the Pro Tracks box. Please review the Pro Tracks documentation to ensure your computer system meets the necessary requirements prior to installation and refer to the **DigiTech Software Installation Guide** for step by step installation instructions. Once installed and configured, the Vx400 can then control Pro Tracks and its recording functions.

Connecting the Vx400 to the Computer

The Vx400 comes equipped with a USB cable that is to be connected to your computer whenever you will be recording or using the X-Edit Editor/Librarian. We recommend that you only use the USB cable that is shipped with the Vx400 since it has been tested and approved for this specific use. To connect the Vx400 to the computer, follow these steps:

- **Before connecting the Vx400's USB jack to your computer, consult the DigiTech Software Installation Guide and follow the instructions for your computers operating system.**
1. Begin with the power disconnected from the Vx400.
 2. Plug the small end of the USB cable in to the USB jack on the back of the Vx400.
 3. Plug the large flat end of the USB cable into an available USB port on your computer.
 4. Connect power to the Vx400.

Vx400 Recording Setup

The Vx400 has several different input / output configurations called Setups offering a wide variety of recording possibilities. These are selected using the **USB 1-2 Source** and **USB 3-4 Source** knobs in the Vx400's effect matrix. For a given recording session, you may want to record a mic with effects, dry mic, instrument, line inputs, a combination of these, or even re-mic your dry vocal tracks back through the Vx400. Up to 4 channels of audio can be sent simultaneously to the computer and the knobs in the **SETUP** row select how and which audio signals are routed up the USB connection. Each USB Source routes a pair of signals to the computer. The following sections outline how these signals are routed:

USB 1-2 Source

STEREO - All input sources that are routed through the Vx400's effects are sent up USB 1 and 2.

MONO - All input sources that are routed through the Vx400's effects are summed to mono and sent up USB 1. Nothing is sent up USB 2

EFFECT - The Effect signal is sent up USB 1 and 2. Stereo track gets recorded.

SUM+DM - All input sources that are routed through the Vx400's effects are summed to mono and sent up USB 1. Dry mic is sent up USB 2.

SUMINS - All input sources that are routed through the Vx400's effects are summed to mono and sent up USB 1. Dry instrument signal is sent up USB 2.

The Vx400 and Recording

- DMIC+I** - Dry Mic signal sent up USB 1. Dry Instrument signal sent up USB 2.
- DRYMIC** - Dry Mic signal sent up USB 1. Nothing is sent up USB 2.
- DRYLIN** - Dry Line Left signal is sent up USB 1. Dry Line Right signal is sent up USB 2. Stereo track gets recorded.
- DRYINS** - Dry Instrument signal is sent up USB 1. Nothing is sent up USB 2.
- DRUMS** - Vx400 drum playback is sent up USB 1. Nothing is sent up USB 2.
- REMIC** - Playback from Pro Tracks™ is sent from the computer back through the Vx400's effects processing, and then sent back up USB 1 and 2 to be recorded. See **Re-micing a Vocal Track** on page 28 for more information on how to use this setting.

USB 3-4 Source

- USBOFF** - USB 3 and 4 are disabled.
- DMIC+I** - Dry Mic signal is sent up USB 3. Dry Instrument signal is sent up USB 4.
- DRYMIC** - Dry Mic signal is sent up USB 3. Nothing is sent up USB 4.
- DRYLIN** - Dry Line Left signal is sent up USB 3. Dry Line Right is sent up USB 4.
- DRYINS** - Dry Instrument signal is sent up USB 3. Nothing is sent up USB 4.
- DRUMS** - Vx400 Drum playback is sent up USB 3. Nothing is sent up USB 4.

The following diagrams show how signals are routed through the Vx400's effects and out the USB port for recording purposes:

Mic Signal Routing

The microphone signal is routed from the mic input through the Vx400's effects processing and then to the pairs of outputs. The signal sent up USB can be tapped off either at the input (**USB Send Path A**), or after the different Effects modules (**USB Send Paths C or D**). Signals recorded from **USB Send Path A** can be played back later through the Vx400 for re-micing. See **Re-Micing a Vocal Track** on page 28 for more information on how this feature works.

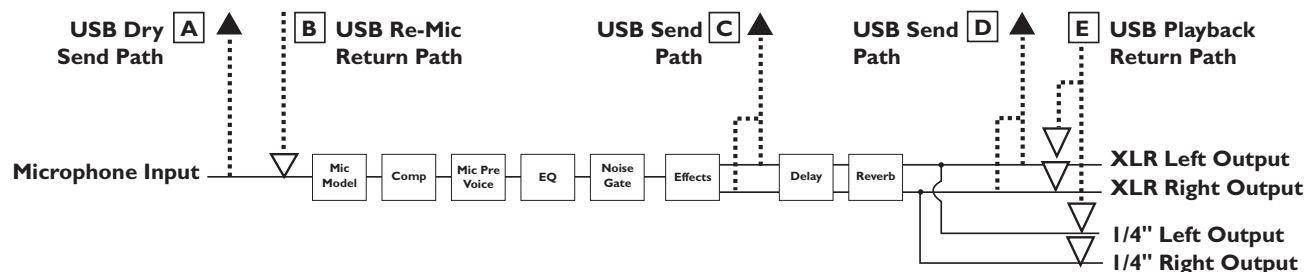

Mic USB Source Mapping

The microphone signal has three paths in which it can travel up the USB port to the computer. Path **A** taps the mic signal off right at the input and sends unprocessed signal up to the USB port. Path **C** taps the mic signal after the Effects modules except the Delay and Reverb. Path **D** taps the mic signal at the output of the Vx400 and can include any effects processing that may be used. Below is a matrix to show where the signal is tapped based on how the **Mic**, **USB 1-2 Source**, and **USB 3-4 Source** settings are configured.

The Vx400 and Recording

Routing of Mic Input to USB

		USB 1-2 Source										USB 3-4 Source							
		STEREO	MONO	EFFECT	SUM+DRY	SUMINS	DMIC+I	DRYMIC	DRYLIN	DRYINS	DRUMS	REMIC	MIC	USBOFF	DMIC+I	DRYMIC	DRYLIN	DRYINS	DRUMS
Mic		D	D	C	A,D	D	A	A	•	•	•	•	•	A	A	•	•	•	•

Instrument Signal Routing

The instrument signal can be routed in different ways through the Vx400. *INSOFF* disables the instrument input from being heard but dry instrument signal can still be recorded. *INSDRY* routes the instrument signal around the Vx400's effects processing and mixes it in at the outputs. *INSRVB* routes the instrument signal only through the Vx400 Delay and Reverb modules. *INSFX* routes the instrument signal through all of the Vx400's effects.

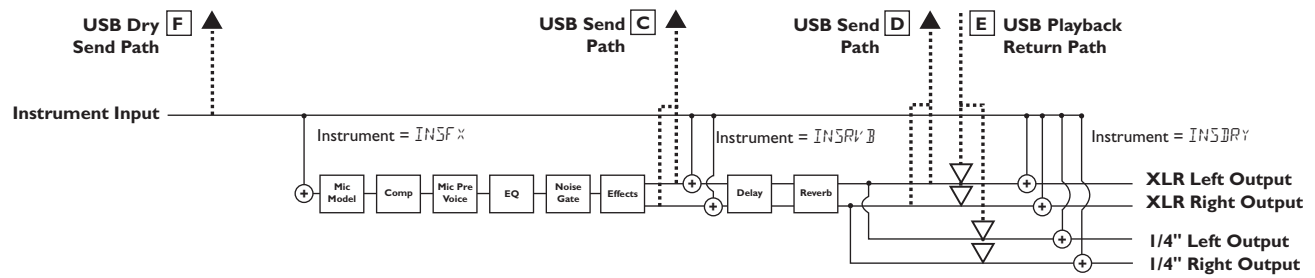

Instrument USB Source Mapping

The instrument signal, as can be seen in the previous Instrument Signal Routing diagram, has two paths in which it can travel up the USB port to the computer. Path **F** taps the instrument signal off right at the instrument input and sends unprocessed signal up to the USB port. Path **C** taps the instrument signal after the different Effects modules except the Delay and Reverb. Path **D** taps the signal at the output of the Vx400 and can include any effects processing that may be used. Below is a matrix to show where the signal is tapped based on how the **Instrument**, **USB 1-2 Source**, and **USB 3-4 Source** settings are configured.

Routing of Instrument Inputs to USB

		USB 1-2 Source										USB 3-4 Source							
		STEREO	MONO	EFFECT	SUM+DRY	SUMINS	DMIC+I	DRYMIC	DRYLIN	DRYINS	DRUMS	REMIC	MIC	USBOFF	DMIC+I	DRYMIC	DRYLIN	DRYINS	DRUMS
Inst.	<i>INSOFF</i>	F	F	F	F	F	F	•	•	F	•	•	•	•	•	•	•	•	•
	<i>INSDRY</i>	F	F	F	F	F	F	•	•	F	•	•	•	•	•	•	•	•	•
	<i>INSRVB</i>	D	D	D	D	F	F	•	•	F	•	•	•	•	•	•	•	•	•
	<i>INSFX</i>	D	D	C	D	F	F	•	•	F	•	•	•	•	•	•	•	•	•

The Vx400 and Recording

Line Signal Routing

The line signals, like the instrument signal, can be routed in different ways through the Vx400. *LINOFF* disables the line inputs from being heard but dry line signal can still be recorded. *LINDRY* routes the left and right line signals around the Vx400's effects processing and mixes them in at the left and right outputs respectively. *LINRVB* routes the line signals only through the Vx400 Delay and Reverb modules. *LINEFX* sums the left and right line input signals together and then routes this signal through all of the Vx400's effects.

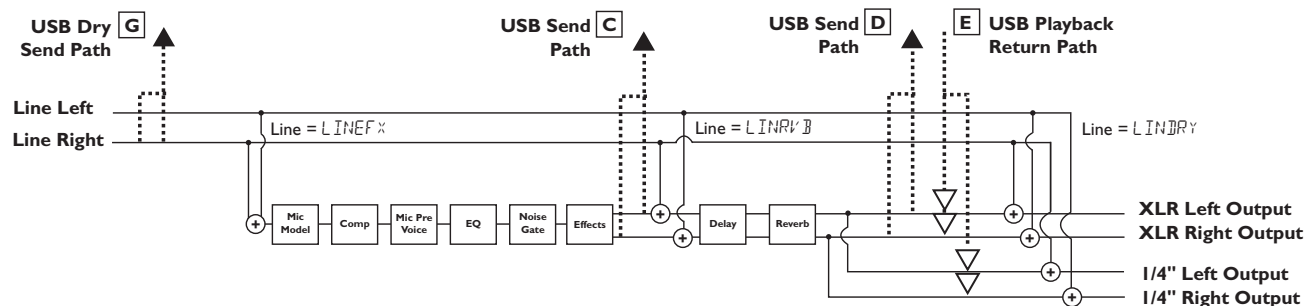

Line USB Source Mapping

The line input signals, as can be seen in the previous Line Signal Routing diagram, has two paths in which they can travel up the USB port to the computer. Path **G** taps the line input signals off right at the line input and sends unprocessed signal up to the USB port. Path **C** taps the line input signals after the different Effects modules except the Delay and Reverb. Path **D** taps these signals at the output of the Vx400 and can include any effects processing that may be used. Below is a matrix to show where the signal is tapped based on how the **Line**, **USB 1-2 Source**, and **USB 3-4 Source** settings are configured.

Routing of Line Inputs to USB

Line	USB 1-2 Source										USB 3-4 Source						
	STEREO	MONO	EFFECT	SUM4 IN	SUMINS	DRYFX	DRYMIC	DRYLIN	DRYINS	DRUMS	REMIC	OFF	DRYFX	DRYMIC	DRYLIN	DRYINS	DRUMS
LINOFF	G	G	G	G	G	•	G	•	•	•	•	•	•	•	G	•	•
LINDRY	G	G	G	G	G	•	G	•	•	•	•	•	•	•	G	•	•
LINRVB	D	D	D	D	D	•	D	•	•	•	•	•	•	•	D	•	•
LINEFX	D	D	C	D	D	•	D	•	•	•	•	•	•	•	D	•	•

The Vx400 and Recording

Using Pro Tracks™

When Pro Tracks is first launched after installation, you will have to configure the MIDI device and Audio settings to recognize the Vx400 as the hardware you want to use. These procedures must be followed to ensure you will be able to record audio through all of the Vx400's inputs and to enable the hands-free recording capabilities the Vx400 offers.

NOTE: Read the Software Installation sheet that came packaged with the Vx400 for instructions on installing USB drivers before connecting the Vx400 to the USB port on your computer and using Pro Tracks.

Installing Pro Tracks Software

Pro Tracks™ software must be installed on your computer in order to use the recording capabilities of the Vx400. To install Pro Tracks, please consult the installation instructions provided with the Pro Tracks installation CD.

Setting Up the DigiTech USB Control

The Vx400 uses MIDI commands through the USB connection to communicate with Pro Tracks. These commands are used to determine which USB 1-2 Source and USB 3-4 Source settings have been selected so that Pro Tracks can function properly when using the Vx400's hands-free recording features. To configure Pro Tracks' MIDI settings for use with the Vx400 follow the steps outlined below:

1. Start Pro Tracks application on your computer.
2. If the **Tip of the Day** window appears, click the **Close** button.
3. If no previous MIDI outputs have been selected, the **No MIDI Outputs Selected** window will appear. Click the **Choose MIDI Outputs Now** button. The **MIDI Devices** window will open.
4. Under both Input and Output Selections, choose **DigiTech USB Control**. Do not select DigiTech USB X-Edit™ or any other available selections. Click the **Move Selected Devices to Top** button.
5. Click the **OK** button and the window will close.
6. If the **Quick Start** window appears, click the **Close** button.

Setting up the Vx400 for Hands-Free Recording

1. From the Pro Tracks menu bar, select **Options>Control Surfaces**. The **Control Surfaces** window will appear.
2. Click the * button to add a new control surface. The **Control Surface Settings** window will open.
3. In the **Control Surface** pull-down menu, select **DigiTech Hands-Free**. Verify that the Input and Output port settings still have **DigiTech USB Control** selected. If they do not, do this now.
4. Click the **OK** button. **Hands-Free** should now be displayed as the **Connected Surface** in the **Control Surfaces Window**.
5. Click the **Close** button.

Pro Tracks can now respond to the Vx400 for automated recording functions.

The Vx400 and Recording

Setting up Pro Tracks™ for Vx400 Audio

1. From the Pro Tracks menu bar, select **Options>Audio**. The **Audio Options** window will appear. Click the **Drivers** tab.
2. Under the **Input Drivers** settings, select **DigiTech USB 1-2 In/Out** and **DigiTech USB 3-4 In Only** and deselect all other options.
3. Under the **Output Drivers** settings, select **DigiTech USB 1-2 In/Out** and deselect all other options.
4. Click the **OK** button.
5. Click the **OK** button when the window stating changes will be saved upon re-start appears.
6. Close the Pro Tracks application. When you are prompted to save changed, click **No**.
7. Re-start the Pro Tracks application again.
8. Close the **Tip of the Day** and **Quick Start** windows if they appear.
9. From the Pro Tracks menu bar, select **Options>Audio**.
10. Verify that the Playback and Record Timing Master settings have **DigiTech USB 1-2 In/Out** selected. If not, select these now.
11. Click the **Wave Profiler** button at the bottom.
12. Click the **Yes** button to continue performing the tests.
13. When the profiling operation is successfully completed, click the **OK** button.
14. Click the **OK** button to close the **Audio Options** window if it is still open.

You are now ready to use the Vx400 with Pro Tracks recording software.

CAUTION: Do not disconnect power or disconnect the USB cable from the Vx400 or the computer while the Pro Tracks software is running. Doing so can result in unpredictable behavior from your computer's operating system.

The Vx400 and Recording

Using the Vx400's Footswitches for Recording

The Vx400's footswitches are capable of controlling the Pro Tracks™ recording software, creating a hands-free recording interface. To do this, the Vx400 must be connected to the computer via the included USB cable and the Pro Tracks application must be installed and open.

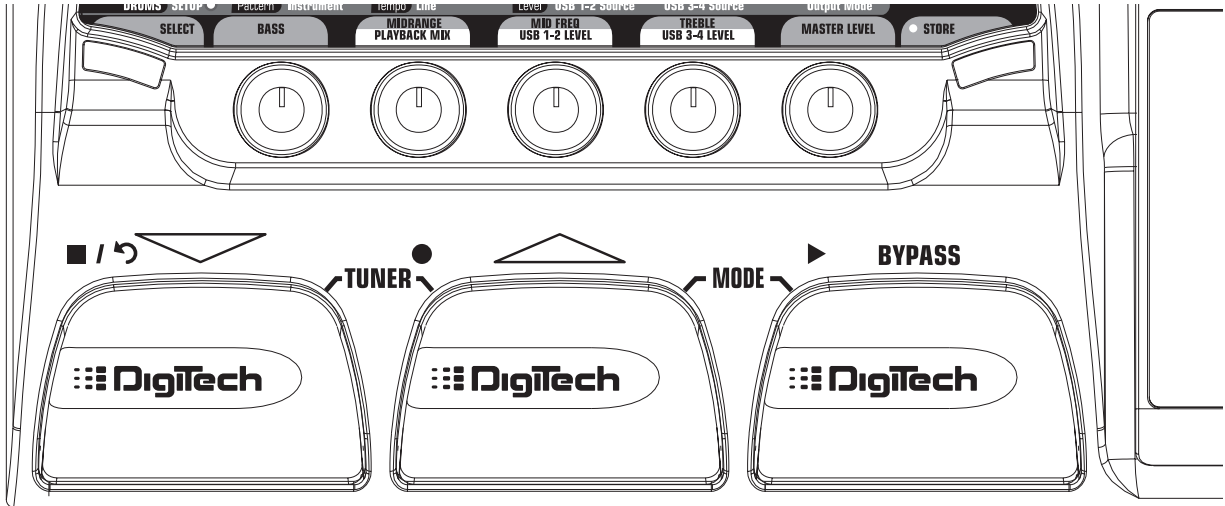

Recording a Track or Tracks

To begin recording a track using the footswitches, follow these steps:

1. Start the Pro Tracks application.
2. From the Pro Tracks menu bar, select **File>New**. The **New Project File** window will appear.
3. From the **New Project File** window, select **Normal - Hands-Free Session**.
4. Put the Vx400 footswitches in Recorder mode by pressing and holding the **UP** and **BYPASS** footswitches simultaneously until the display reads *REC FS*.
5. From the preset display, press and hold the **SELECT** button to enter the **SETUP** row in the Vx400's matrix. Otherwise, press the **SELECT** button several times until the setup row is selected.
6. Select the sources to record using the **USB 1-2 Source** knob (additional sources can be selected using the **USB 3-4 Source** knob).
7. Press the **RECORD** footswitch. The Vx400's display reads *RECORD*. A track or tracks are automatically inserted in the current session of the Pro Tracks software and recording on these tracks begins.
8. To stop recording, press the **STOP/UNDO** footswitch. The Vx400's display reads *STOP* and Pro Tracks stops recording. The wave data for the track(s) can now be viewed on your computer monitor.

Playing Back a Recorded Track

After a track or tracks have been recorded, playing them back is easy. If you want to start playback at the beginning of a track or song but are someplace other than the end of the song, follow these steps:

1. Press the **STOP/UNDO** footswitch once. The Vx400 display will read *REWIND*. Pro Tracks will rewind to the beginning of the current song.
2. Press the **PLAY** footswitch. The recorded track(s) will begin playing back.

The Vx400 and Recording

Recording Multiple Tracks

After tracks have been recorded, you may want to record other tracks that play along with them. To record a new track or tracks with previously recorded tracks, follow these steps:

1. From the preset display, press and hold the **SELECT** button to enter the **SETUP** row in the Vx400's matrix.
2. Select the sources to record using the **USB 1-2 Source** knob (additional sources can be selected using the **USB 3-4 Source** knob).
3. Press the **STOP/UNDO** footswitch twice. This will rewind to the beginning of the current song.
4. Press the **RECORD** footswitch. The Vx400's display reads *RECORD*. A track or tracks are automatically inserted in the current session of the Pro Tracks software and recording on these tracks begins.
5. To stop recording, press the **STOP/UNDO** footswitch.

Using the UNDO Footswitch to Erase a Track

You can undo the last take or previous tracks using the Vx400's footswitches. To undo tracks, follow these steps:

1. Press and hold the **STOP/UNDO** footswitch. The Vx400's display reads *UNDO*, indicating the last recorded track(s) are being deleted.

Re-Micing a Vocal Track

Using one of the Dry Microphone configurations for recording gives you the opportunity of playing that dry take back into the Vx400 for re-processing. The advantages of having this feature are you can experiment playing the dry vocal take back through different mic models, voice types, effects, or entirely new presets once you have your other tracks recorded. This helps when trying to fit a vocal effect into a mix after the song is assembled rather than recording with effects that can't be undone.

To re-mic a track back through the Vx400, follow these steps:

1. Put the Vx400 footswitches in Recorder mode by pressing and holding the **UP** and **BYPASS** footswitches until the display reads *REC FS*.
2. From the Pro Tracks menu bar, select **File>New**. The **New Project File** window will open.
3. Select the **Normal-Hands-Free Session** project template.
4. Select the **SETUP** row in the Vx400's matrix.
5. Use the **USB 1-2 Source** knob to select *DRYMIC* and **USB3-4 Source** to *OFF*.
6. Press the **RECORD** footswitch. The Vx400's display reads *RECORD*. A track is automatically inserted in the current session of the Pro Tracks™ software and recording on this track begins.
7. To stop recording, press the **STOP/UNDO** footswitch. The Vx400's display reads *STOP* and recording will stop. Press Stop again to rewind to the beginning of the track.

The Vx400 and Recording

8. In the **Out** box of the track you just recorded, select **B(Digitech USB 1-2 In/Out)**.

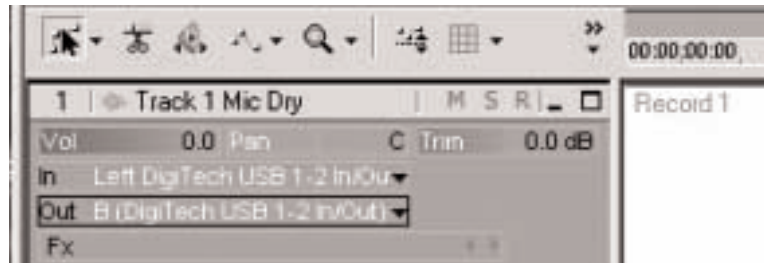

9. In the tool bar press the **Console View** button to see the mixing console.

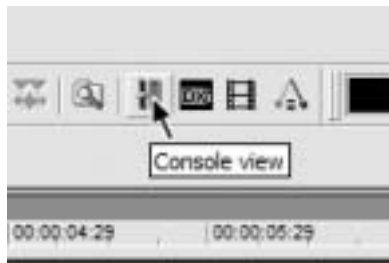

10. Pan the **B - Mains Output** hard left and the **A - Mains Output** hard right.



11. Select the **SETUP** row again and use the **USB 1-2 Source** knob to select *REMIC*. This configures the recording software to playback audio through the Vx400's effects processing.
12. Press the **PLAY** footswitch. Put the footswitches back to Performance mode by pressing and holding the **UP** and **BYPASS** footswitches simultaneously until the display reads *UP/DOWN*. You can now audition presets until you find one you like. Once you have done so, return to Recorder footswitch mode.
13. Press the **STOP/UNDO** footswitch twice to rewind to the beginning of the track.
14. Press the **RECORD** footswitch and the recorder will now insert and record a stereo track of processed mic or vocals.
15. To stop recording, press the **STOP/UNDO** footswitch.

The Vx400 and Recording

Vx400 Drums and MIDI

The Vx400's Drum machine samples are mapped so that they may be triggered by MIDI notes played from Pro Tracks™. Each of the drum patterns programmed in the Vx400 has been programmed as a MIDI track in the Pro Tracks project file library.

Note mapping for each of the Vx400's drum samples is as follows:

MIDI Note	Sample
36/C3Kick
38/D3Snare
42/F#3Closed High Hat
46/Bb3Open High Hat

Recording the Vx400 Drums



The Vx400's drum machine can be recorded using Pro Tracks. Each of the Vx400 drum patterns have been saved as pattern template files which can be selected from the Pro Tracks project file library for playback control of the Vx400's drum samples. To record the Vx400 drums using the pattern templates provided in Pro Tracks, follow these steps:

1. From the Pro Tracks menu bar, select **File>New**. The **New Project File** window will appear.
2. Select one of the DigiTech Vx400 drum templates and click the **OK** button. This will open up a new recording session.
3. On the Vx400, use the either **USB 1-2 Source** or **USB 3-4 Source** knobs to select **DRUMS**.
4. Press the **RECORD** footswitch. The Vx400's display reads **RECORD**. A new track is automatically inserted in the current session of the Pro Tracks software and recording on these tracks begins.
5. To stop recording, press the **STOP/UNDO** footswitch.

You can use MIDI drum files for playing the Vx400 drum samples if you like as long as the events are mapped to the MIDI notes shown above. The drum samples of the Vx400 only respond to MIDI messages transmitted on MIDI channel 10, which is the default channel for General MIDI drums.

Playback Mix

The **PLAYBACK MIX** knob is an easy way to balance the Vx400's processing with playback from the Pro Tracks software using a single control. This function is only available when the Vx400 is connected to the computer via USB and Pro Tracks is up and running. To change the Vx400/Playback mix, follow these steps:

1. Start playback of a session from Pro Tracks.
2. Turn the playback mix knob to balance the level of Vx400 vocal processing and playback level. When the display reads **USB MIX**  indicates that only Vx400 signals will be heard. Rotating this knob clockwise, you will begin to hear the playback level increase. **USB Vx50** indicates the Vx400/computer playback mix is a 50/50 mix of both signals. Continuing to rotate the knob clockwise will decrease Vx400 level. **Vx MIX**  indicates that only playback from the computer will be heard.

USB 1-2 Level /USB 3-4 Level

The **USB 1-2 LEVEL** and **USB 3-4 LEVEL** knobs are used for boosting or cutting the amount of signal sent out the USB port to the computer. These controls are to be used if the signal level of the input source (mic, line, instrument) isn't optimized into your recording software (consult the Pro Tracks User's Guide for information on proper recording levels). If the signal is too hot to Pro Tracks, use these controls to decrease the level. The USB 1-2 Level and USB 3-4 Level knobs control the level for each USB pair of outputs so for example, if *SUMMIE* is the selected USB 1-2 Source, increasing the level for the mic 6dB going up USB 2 will also increase the summed signal by 6dB going up USB 1. To increase or decrease the level of audio going up to the computer, follow these steps.

1. Sing/play through the Vx400 and check the level of signal reaching the recording software (consult the Pro Tracks User's Guide for information on how to view recording signal levels).
2. Use which ever USB Level knob to boost or cut the signal level going to the recording software. The boost/cut range are -6db (USB 1-2 -6) to +24dB (USB 1-2 24).

Using the RPxFC for Recorder Functions

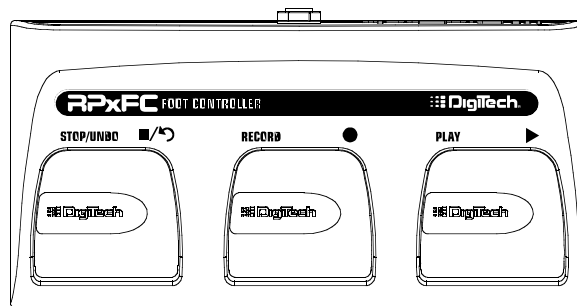

The Vx400 is equipped with a footswitch jack that lets you connect an optional RPxFC for controlling the Vx400's recorder. This 3-button footswitch features functions for **STOP/UNDO**, **RECORD**, and **PLAY**. The RPxFC is an ideal companion for recording as it lets you leave your Vx400 footswitches setup for changing presets while the RPxFC is used specifically for controlling the Pro Tracks recording software. Use only a TRS stereo 1/4" cable when connecting the RPxFC to the Vx400.

The RPxFC functions are exactly the same as the Vx400 footswitches when it is in Recording mode. Refer to section **Using the Vx400's Footswitches for Recording** for operating instructions.

Utilities

Factory Reset

This function resets the Vx400 to its original factory settings. This procedure erases all custom user presets, and recalibrates the Expression Pedal.

ATTENTION: Performing this function erases all user-programmed data. Be sure you want to erase the memory and start fresh before continuing with this procedure.

The procedure for performing a Factory Reset is as follows:

1. Disconnect the power supply from the Vx400.
2. Press and hold the Select button while re-connecting the power to the Vx400.
3. When the display reads *RESET?*, release the Select button and press the Store button. The display reads *RESET* indicating that the Vx400 has reset the original factory settings. At this point, the Vx400 automatically advances to the Expression Pedal calibration menu. Follow steps 4 through 7 of the Expression Pedal calibration section.

Expression Pedal Calibration

The Expression Pedal needs to be recalibrated after a factory reset. This function is automatically prompted after a factory reset. In the event the pedal's calibration fails, or if the pedal does not function properly, it can be re-calibrated using the Pedal Calibration function. This does not erase the User Presets. The procedure for Calibrating the Expression Pedal is as follows:

1. Disconnect the PS0913B power supply from the power jack on the Vx400.
2. Press and hold the Down Footswitch while re-connecting the power.
3. Continue to hold the Down Footswitch until the display briefly reads *calib* (calibration).
4. When the display reads *TOE DN*, rock the Expression Pedal forward to the toe down position.
5. Press any footswitch. The display reads *TOE UP*.
6. Rock the Expression Pedal back to the toe up position.
7. Press any footswitch. The display reads *VSWITCH* indicating you have entered the V-Switch Sensitivity menu.
8. If you do not want to adjust the V-Switch sensitivity, press any footswitch to return to Performance Mode.

Note: If error displays, an error has occurred and steps 4 through 8 should be repeated.

V-Switch Sensitivity

If you want to adjust the sensitivity setting of the V-Switch, follow steps 1 through 7 of Calibrating the Expression Pedal and then follow the steps listed below:

1. When the display reads *VSWITCH*, rock the Expression Pedal forward (toe down) and apply extra pressure on the toe of the pedal until the display reads *DONE*.
2. When display alternates between *DONE* (with the V-Switch sensitivity value in the numeric Display) and *VSWITCHON* (or *VSWITCHOFF* depending on whether the V-Switch is on or off), you can audition the V-Switch sensitivity by applying pressure to the toe of the Expression Pedal.
3. Rotate the Number 5 Knob to change the value of the V-Switch sensitivity. You can audition the new value by applying pressure to the toe of the Expression Pedal.
4. Once the sensitivity value is selected, press any footswitch. The Vx400 returns to Performance Mode and your settings are automatically saved.

Trouble Shooting Guide

Audio playback from Pro Tracks™ has pops and clicks.

- Try the **Wave Profiler** under **Options->Audio**. This seems to fix most problems. Otherwise, try using MME drivers in the **Options->Audio->Advanced, Driver Mode** selection. These are the safest drivers but also have the most latency.
- Try increasing the latency slider in the audio settings.

Hands-Free recording on Vx400 doesn't work or has stopped working.

- If it was working at one point but has stopped working, try exiting Pro Tracks and then restarting it (make sure to save your project).
- Cycle power to the Vx400 before entering Pro Tracks or X-Edit.
- If it has never worked at all, there is a problem with USB MIDI. The most probable causes are using incorrect or incorrectly installed drivers and/or .dll or a bad USB cable.
- See the section on driver installation.

I can't hear audio playback from Pro Tracks.

- If the 'Remic' mode in the Vx400 is active try switching to a different mode like 'Stereo'.
- Make sure the faders in Pro Tracks are turned up.
- Check that the tracks you want to playback are un-muted.
- Go to **Options->Audio->Drivers** and under output drivers, select '**DigiTech USB 1-2 In/Out**' and de-select everything else.
- See the section on driver installation.

My Vx400 doesn't record to Pro Tracks.

- Go to **Options->Audio->Drivers** and under input drivers, select '**DigiTech USB 1-2 In/Out**' and '**DigiTech USB 3-4 In Only**'. De-select everything else.
- Make sure the proper drivers are installed.
- See the section on driver installation.
- For an initial track, make sure 'REMIC' mode in the Vx400 is not used.

I can't get Re-Micing to work.

- See the **Re-Micing a Track** section of this user's guide.

Pro Tracks intermittently locks up.

- Close any other open programs besides Pro Tracks. Check "Task Manager" to make sure there are no hidden programs running.
- Try reducing the number of plug-ins and soft-synths.
- Increase the amount of memory in your system.
- Get a faster hard drive.
- Put your audio data on a different hard drive from your OS and applications.
- Get a faster computer.
- Please refer to the system requirements section.

Where did my wave files go?

- Wave files all get saved to the folder specified in **Options->Global, Audio Data**.

My waves are low/too high in level.

- The recording signal level can be boosted or reduced using the USB1-2 and USB3-4 level controls.

Pro Tracks playback is louder than my voice.

- You can adjust the mix of playback versus microphone by using the Playback mix knob.

Trouble Shooting Guide

I get audio dropout while I'm recording.

- Try increasing the latency slider in the Audio settings.
- Try reducing the number of tracks in your project (mute won't help, you either have to "archive" the tracks, or delete them)
- Close any other open programs besides Pro Tracks check Windows **Task Manager** to make sure there are no hidden programs running.
- Try reducing the number of plug-ins and soft-synths.
- Increase the amount of memory in your system.
- Get a faster hard drive.
- Put your audio data on a different hard drive from your OS and applications.
- Get a faster computer.

When I launch X Edit, it can't find the Vx400.

- Make sure your drivers are loaded correctly and that the USB cable is inserted securely.
- See the section on **USB Driver installation**.

I hear doubling of the playback.

- Input monitoring is probably active. Go to **Options->Audio->Input Monitoring** to disable.

Mid, MidFreq. and Treble controls are not working.

- When USB is connected, the Mid, Mid Freq. and Treble controls function as **Playback Mix, USB 1-2 Level, and USB 3-4 Level** controls. The tone controls can still be accessed from the editing matrix or from X Edit.

My instrument input didn't record.

- Dry instrument can only be recorded on a separate track, not as part of a mix. To record the instrument in, go to the setup level of the matrix and select *DRYINS* in **USB1-2 Source** or **USB3-4 Source**.
- Instrument with reverb or effects can be recorded as a mix with the microphone. The **Mic** setup must be set to either *INSRVB* or *INS FX*.

My drums didn't record.

- Drums can only be recorded on a separate track, not as part of a mix. To record drums, go to the setup level of the matrix and select *DRUMS* in **USB1-2 Source** or **USB3-4 Source**.

My line inputs didn't record.

- Dry line inputs can only be recorded on a separate track, not as part of a mix. To record line inputs, go to the setup level of the matrix and select *DRYLIN* in **USB1-2 Source** or **USB3-4 Source**.
- Line with reverb or effects can be recorded as a mix with the microphone. The Line selector must be set to either *LINRVB* or *LINEFX*.

I get dropout when I change presets during recording/playback.

- Changing presets during recording/playback will cause dropout of audio.

My mic/line inputs had dropout while I was recording.

- Changing presets while recording will cause dropout of audio to and from the computer.

Pro Tracks won't launch.

- This was probably caused by interrupting the USB connection while in a previous Pro Tracks session. You must reboot your system to fix this problem.

I don't hear playback from USB 3-4.

- Playback is only available on USB 1-2. USB 3-4 is used for additional track recording - like dry instrument, mic, drums, etc.

Appendix

CC Parameter List

CC	Parameter	CC	Parameter
12	MIC ON/OFF	4	GLB PEDAL1POSITION
13	MIC SOURCE	7	GLB MASTER LEVEL
14	MIC MODEL	75	GLB INSTRUMENT ROUTE
15	COMP ON/OFF	76	GLB LINEIN ROUTE
16	COMP TYPE	77	GLB USB1 ROUTE
17	COMP GAIN	78	GLB USB2 ROUTE
18	VOICE ON/OFF	79	GLB OUTPUT ROUTE
19	VOICE TYPE	80	GLB USB1 LEVEL
20	VOICE PARAM1	81	GLB USB2 LEVEL
21	VOICE PARAM2	82	GLB USB MIX
22	VOICE LEVEL		
23	VOICE BYPASSLVL		
24	EQ MIDFREQ		
25	EQ BASS		
26	EQ MIDRANGE		
27	EQ TREBLE		
28	GATE ON/OFF		
29	GATE THRESH		
30	FX ON/OFF		
31	FX TYPE		
32	FX PARAM1		
33	FX PARAM2		
34	FX LEVEL/MIX		
35	DLY ON/OFF		
36	DLY TYPE		
37	DLY TIME		
38	DLY FEEDBACK		
39	DLY LEVEL		
40	RVB ON/OFF		
41	RVB TYPE		
42	RVB DAMP		
43	RVB DECAY		
44	RVB LEVEL		
45	PDL1 ASSIGN		
46	PDL1 MIN		
47	PDL1 MAX		
48	PDL2 ASSIGN		
49	PDL2 MIN		
50	PDL2 MAX		
51	PDL3 ASSIGN		
52	PDL3 MIN		
53	PDL3 MAX		

Appendix

Factory Preset List

Number	Preset Name	Display Name	Number	Preset Name	Display Name
1/41	Vocal Delay	VOCDELAY	21/61	Wizard	WIZARD
2/42	Monster	MONSTER	22/62	Warm Tube Delay	TUBDELAY
3/43	50's Slapback Delay	SLAPBK	23/63	Distorted Tremolo	DSTREM
4/44	Grunge Vocal	GRUNGE	24/64	Karaoke Delay	KARAKE
5/45	Thicken	THICKN	25/65	Mars Man	MARS
6/46	Vocal Plate	PLATE	26/66	Whammy Man	WHAMAN
7/47	Wah Voice	WAHVOIC	27/67	Big Verb	BIGVRB
8/48	Vibrato	VIBRTO	28/68	Distorted Delay	DSTDELAY
9/49	Tube Mic Preamp	TUBPRE	29/69	Helium	HELIUM
10/50	Oh Yeah!	OHYEAH	30/70	Cyborg	CYBORG
11/51	Breathy	BRETHY	31/71	Billy Goat	GOAT
12/52	5th Up Pitch Shift	5TH UP	32/72	Invaders	INVADR
13/53	Telephone	TELPHN	33/73	Megaphone	MEGPHN
14/54	Alvin	ALVIN	34/74	Chorus Verb	CHORVRB
15/55	Strobvoice	STROBE	35/75	Wiggly	WIGGLY
16/56	Rich Detune	DETUNE	36/76	Monster Pong	MONPNG
17/57	Lo-Fi	LO FI	37/77	Robot	ROBOT
18/58	Phased Pong	PHSPNG	38/78	Stutterer	STUTTR
19/59	Compressed	CMPRSSD	39/79	Pixelator	PIXLTR
20/60	Dark Force	FORCE	40/80	Space Reverb	SPACE

Specifications:

Inputs:

Instrument In: 1/4" Unbalanced
Mic In: XLR Balanced w/Phantom Power
Line Inputs: 1/4" Balanced TRS
CD/Monitor: 1/8" Stereo TRS
Footswitch: 1/4" Stereo TRS
USB I.I

Outputs:

Line Outputs: 1/4" Unbalanced
Line Outputs: XLR Balanced
Headphone: 1/8" Stereo TRS
USB I.I

A/D/A:

24 bit Delta Sigma Converters

Drum Machine:

30 Patterns + Metronome

Simultaneous Effects:

up to 8

Power Consumption:

10 Watts,

Current Draw:

675mA AC

Power Supply:

9 VAC, 1300mA
DigiTech PS0913B - 100 (100V ~ 50/60Hz)
DigiTech PS0913B - 120 (120V ~ 60Hz)
DigiTech PS0913B - 230 (230V ~ 50Hz)
DigiTech PS0913B - 240 (240V ~ 50Hz)

Preset Memory:

40 User Presets
40 Factory Presets

Effects:

Microphone Models, Compressor, Noise Gate, Mic Pre / Voice, EQ, Chorus, Flanger, Phaser, Tremolo, Vibrato, Strobe, Doubler, Envelope, Pixelator, Detune, Pitch, Whammy™, Delay, and Reverb.

Dimensions:

8.5" L x 13" W x 2.25" H

Weight: 4.65 lbs.

DigiTech
8760 S. Sandy Parkway
Sandy, Utah 84070
PH (801) 566-8800 FAX (801) 566-7005

International Distribution
8760 S. Sandy Parkway
Sandy, Utah 84070 USA
PH (801) 566-8800 FAX (801) 566-7005

**DigiTech and Vx400 are trademarks of the
Harman Music Group Inc.**

Copyright the Harman Music Group

**Manufactured and
Printed in the USA 06/2003**

Vx400 User's Guide 18-1799-A

**Please visit DigiTech on the World Wide Web at:
<http://www.digitech.com>**